



Continuous Inkjet

# Videojet 1610 Dual Head

The 1610 Dual Head delivers superior uptime with automatic set up and maintenance features for twice the productivity.

The Videojet 1610 Dual Head continuous inkjet printer is designed for applications requiring printing in two locations on the same product or on multiple lanes on a web application, delivering 12,000 hours of operation before required preventive maintenance.

The 1610 Dual Head is ideal for the food and beverage, pharmaceutical, tobacco and building materials markets.



## Uptime Advantage

- Long run time between preventive maintenance – 12,000 hour core life
- CleanFlow™ printhead technology reduces ink build-up, lets you run longer between printhead cleanings and helps ensure consistently sharp print quality

## Built-in productivity

- Dual printheads can be run independently or in tandem to meet a wide range of applications
- IP65 dust protection (no plant air required)
- Up to 5 lines of high resolution print per printhead with speeds up to 960 fpm (293mpm)

## Code Assurance

- Prevent costly coding mistakes with CLARITY™-based user interface
- Foolproof set-up wizards make it easy to get codes right and hard to get them wrong
- Further reduce errors by pulling data directly from database systems

## Simple usability

- SmartCartridge™ fluid delivery system prevents spills and drains completely to eliminate waste
- Automatic printhead set up, calibration and adjustment for consistent performance

# Videojet® 1610 Dual Head

## Continuous Inkjet

### Line speed capability (per head)

Can print 1 to 5 lines of print at speeds of up to 960fpm (293mpm)  
(10 characters per inch, single line of print)

### Font matrix configuration

Single-line: 5x5, 4x7, 5x7, 7x9, 9x12, 10x16, 16x24, 25x34  
Twin-line: 5x5, 5x7, 7x9, 9x12, 10x16  
Tri-line: 5x5, 4x7, 5x7, 7x9  
Quad-line: 5x5, 4x7, 5x7  
Five-line: 5x5

### Linear bar codes

UPC A&E; EAN 8 & 13; Code 128 A, B & C; UCC/EAN 128;  
Code 39; Interleaved 2 of 5; 2D DataMatrix; GS1

### DataMatrix codes

10x10, 12x12, 14x14, 16x16, 8x18, 18x18, 20x20, 22x22, 24x24, 16x26, 26x26, 8x32,  
32x32, 34x34, 12x36, 16x36, 16x48

### Nominal character height

Selectable from 0.079" (2mm) to 0.40" (10mm), depending on font

### Throw distance

Optimal: 0.472" (12mm)  
Range: 0.197" (5mm) to 0.591" (15mm)

### Keyboard

Membrane style with tactile feedback, including 72 numeric, alphabetic, and special function keys. PC-style layout to approximate international PC convention.

### Display

320x240 Bright blue backlit 5.7" LCD display  
WYSIWYG onscreen message editing

### Custom logo/graphics

Can be created by individual user on printer or PC with optional Videojet Logo Creator software

### Character sets

Chinese, Russian/Bulgarian, Turkish/Scandinavian, Greek, Arabic, Japanese/Kanji, Hebrew, Korean, East European and European/American

### Languages and interface options

English, Arabic, Bulgarian, Czech, Danish, Dutch, Finnish, French, German, Greek, Hebrew, Hungarian, Italian, Japanese, Korean, Norwegian, Polish, Portuguese, Russian, Simple Chinese, Spanish, Swedish, Thai, Traditional Chinese, Turkish and Vietnamese

### Data interface

RS232, RS485 and ethernet (standard)  
CLARISOFT™/CLARINET™ via RS232 and ethernet  
Message management via USB

### Message storage

250 complex messages

### Environmental protection

IP65 standard, no plant air required; stainless steel cabinet

### Printheads

Heated printhead  
Positive air (standard)  
Automatic calibration  
Auto-clean design  
Diameter: 1.63" (41.3mm)  
Length: 10.62" (269.8mm)

### Printhead umbilicals

Ultra flexible  
Length: 9.84' (3m) optional 19.69' (6m)  
Diameter: 0.91" (23mm)  
Bend radius: 4.00" (101.6mm)

### Fluids containers

Ink Smart Cartridge™ 0.793 qt. (750ml)  
Make-up Smart Cartridge 0.793 qt. (750ml)

### Temperature/humidity range

32°F to 122°F (0°C to 50°C)

0% to 90% RH non-condensing

*With selected inks; actual installation may require additional hardware based on production environment conditions*

### Electrical requirements

Nominal supply power 100-120 / 200-240 VAC at 50/60 Hz, 120 W

### Approximate weight

Unpacked and dry: 48.6lbs. (22kg)

### Options

Dry air kit for high humidity (requires plant air)  
Food grade version  
60 or 70 micron nozzle  
90 degree printhead  
Wide range of accessories

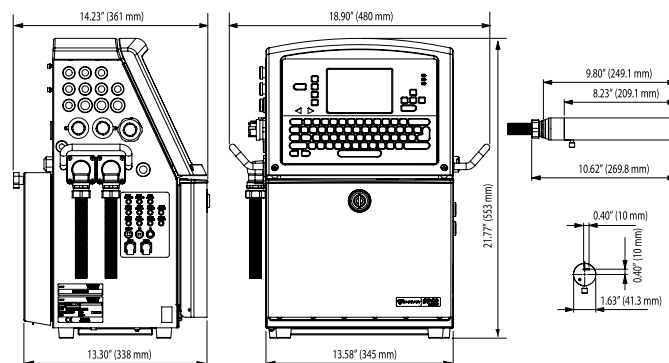

CERTIFIED  
ISO 9001  
DOCUMENTED QUALITY



Schur Automation a/s  
Fuglevangsvej 41 - DK-8700 Horsens  
Tel. +45 79 28 29 28  
www.schur.com - marking@schur.com

©2019 Videojet Technologies Inc. — All rights reserved.

Videojet Technologies Inc.'s policy is one of continued product improvement. We reserve the right to alter design and/or specifications without notice.

Part No. SL000501  
ss-1610dh-us-0919  
Printed in U.S.A.

