



VIDEOJET

Schur

Thermal Transfer Overprinting

Videojet DataFlex® 6330

The Videojet DataFlex® 6330 includes iAssure™ technology, a built-in code quality checker to help reduce waste and rework with no additional hardware, installation or training.

The Videojet DataFlex® 6330 is built to withstand tough production line environments. Designed for simple maintenance with minimal wear parts and easy-to-change ribbon to give an overall more productive operation.

Offering print speeds of up to 750mm/s and throughputs up to 250 ppm¹, the 6330 is available in a 53mm printhead and a 32mm printhead for smaller printing areas.



Uptime Advantage

- Reduce costs and downtime, maximize printhead life and gain consistent print quality thanks to airless Videojet Intelligent Motion™ technology
- Up to 1,200m ribbon capacity and a variety of ribbon economy modes help maximize the time between ribbon changeovers

Built-in productivity

- Using default settings you can maintain consistent code quality and avoid conventional air and energy settings that operators might over-adjust
- Quickly discover code legibility issues that indicate the potential need for printer maintenance
- Industry-leading simple cassette change designed for fast ribbon replacement to maximize uptime
- 25% faster throughput than previous Videojet TTO models

Code Quality Assurance

- Videojet iAssure™ technology, a built-in code quality checker, helps reduce waste and rework with no additional hardware, installation or training
- Videojet CLARiTY™ software helps ensure the right code is consistently printed on the right product

Easy usability

- Simple operator interface
- Designed to withstand tough production line environments
- Minimal wear parts are easy to change out, improving production line uptime

¹ Application and substrate dependent. iAssure™ technology is not currently supported for use with all ribbon savings modes.

Videojet DataFlex® 6330

Thermal Transfer Overprinting

Printhead

32 or 53mm, 300dpi (12dot/mm)

Print area

32mm intermittent printing mode: 1.3" (32mm) wide x 3.0" (75mm) long
32mm continuous printing mode: 1.3" (32mm) wide x 7.9" (200mm) long
53mm intermittent printing mode: 2.1" (53mm) wide x 3.0" (75mm) long
53mm continuous printing mode: 2.1" (53mm) wide x 7.9" (200mm) long

Minimum print speed¹

Intermittent mode: 1.6 in./sec (40mm/sec) full print quality; 0.4 in./sec (10mm/sec) draft mode print quality
Continuous mode: 1.6 in./sec (40mm/sec) full print quality; 0.04 in./sec (1mm/sec) draft mode print quality

Maximum print speed¹

29.5 in./sec (750mm/sec)

Maximum throughput¹

Up to 250 prints per minute

Printing capabilities

Full downloadable font support using TrueType® fonts (including multiple languages and Unicode support); fixed, variable and merged text fields; flexible date/time formats; flexible shift code formats; auto best before date calculations and concession management; calendar rules; auto incrementing decrementing text, counters and bar codes; multiple graphic formats supported (up to maximum print area); link fields to databases; scalable text and text blocks

Bar codes

EAN 8, EAN 13, UPC-A, UPC-E, Code 39, EAN 128, Code 128, ITF, RSS (including 2D composite codes), DataMatrix, QR; others available upon request

Operator interface

TFT SVGA 800x480 full-color LCD and touch screen, WYSIWYG print preview, full on-board diagnostics, 3 levels of password protection, extensive language support

Ribbon range

Full assortment of wax/resin and resin ribbons

Maximum ribbon length

Lengths up to 1,200 meters available, dependent on ribbon composition and color

Ribbon widths

53mm: 0.8" (20mm) min, 2.2" (55mm) max
32mm: 0.8" (20mm) min, 1.3" (33mm) max

Nominal gap between successive prints

0.02" (0.5mm)

Ribbon saving features

Radial, interleaved, intermittent stripes

Image design software

Videojet CLARISOFT™, CLARISUITE® or VideojetConnect™ Design Template Management software

Network management software

CLARINET™

Remote coder configuration software

CLARITY™ Configuration Manager
"Off-line" set up and parameter storage available as standard

Standard installation options leader/follower configuration

Up to four Videojet DataFlex® 6330 printers controlled via a single CLARITY control unit

Web browser mode

Control Videojet DataFlex® 6330 units remotely through the host packaging machine interface

External communications

RS232, dual Ethernet, USB memory stick and scanner support, Binary and ASCII comms protocols, Windows® drivers, ZPL and SATO emulations

External inputs/outputs

3 PNP inputs
2 relay outputs and 2 PNP +24V outputs

Power supply

100-240VAC

Operating temperature

0-40°C (32-104°F)²

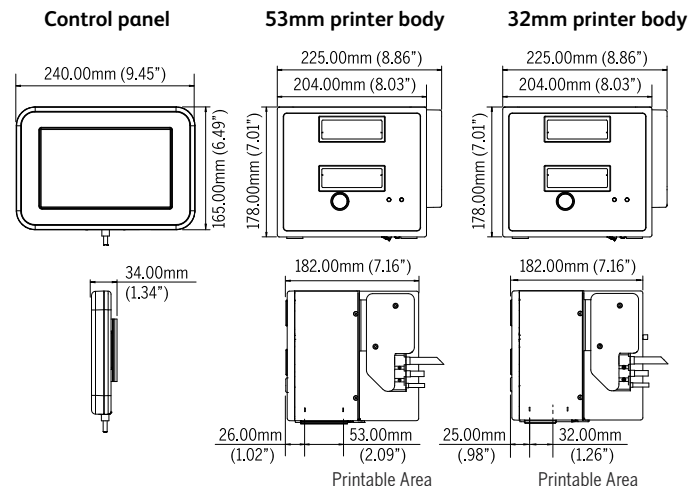

¹ Application dependent

² With selected ribbons. Actual installation may require additional hardware based on production environment.

CERTIFIED
ISO 9001
DOCUMENTED QUALITY



Schur Automation a/s
Fuglevangsvej 41, 8700 Horsens
Tel. +45 79 28 29 28
www.schur.com - marking@schur.com

©2020 Videojet Technologies Inc. — All rights reserved.

Videojet Technologies Inc.'s policy is one of continued product improvement. We reserve the right to alter design and/or specifications without notice. TrueType is a registered trademark of Apple Inc., registered in the United States and other countries. Windows is a registered trademark of Microsoft Corporation in the United States and/or other countries.

Part No. SL000648
ss-6330-us-1020
Printed in U.S.A.

